

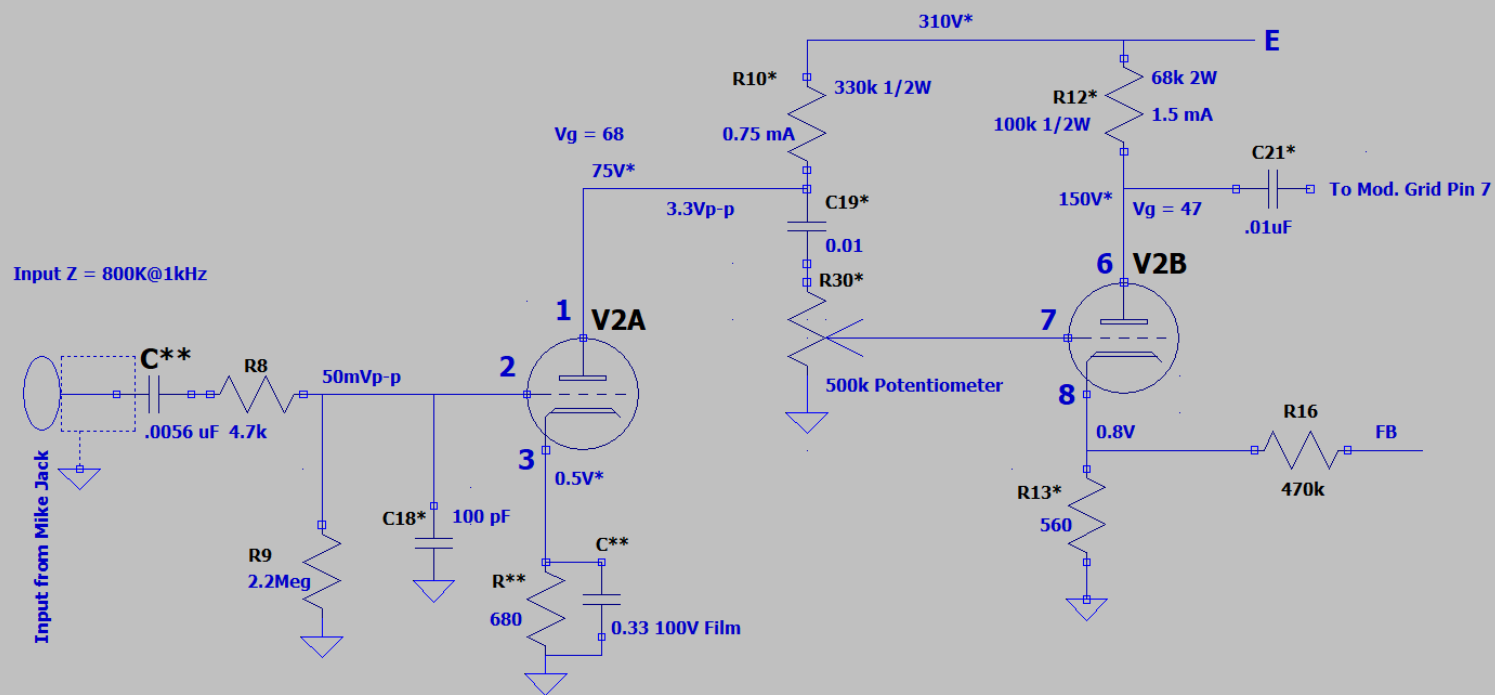

## Knight T-60 12AX7A Speech Amp Stage

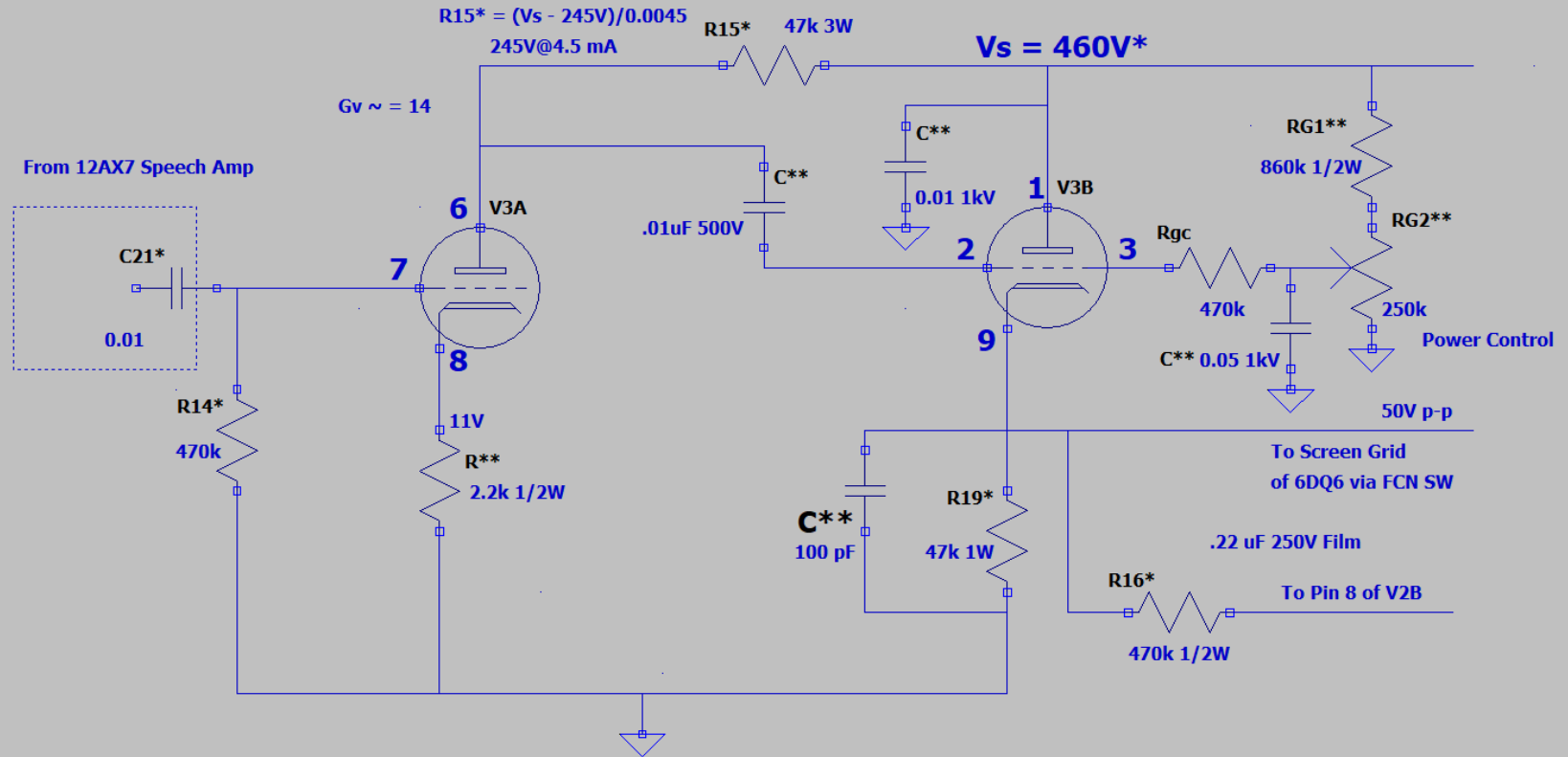

# Knigh T- 60 Modulator Stage V3 6DE7 with Power Control



# Knight T- 60 Osc. Mult. Driver using 6CL6

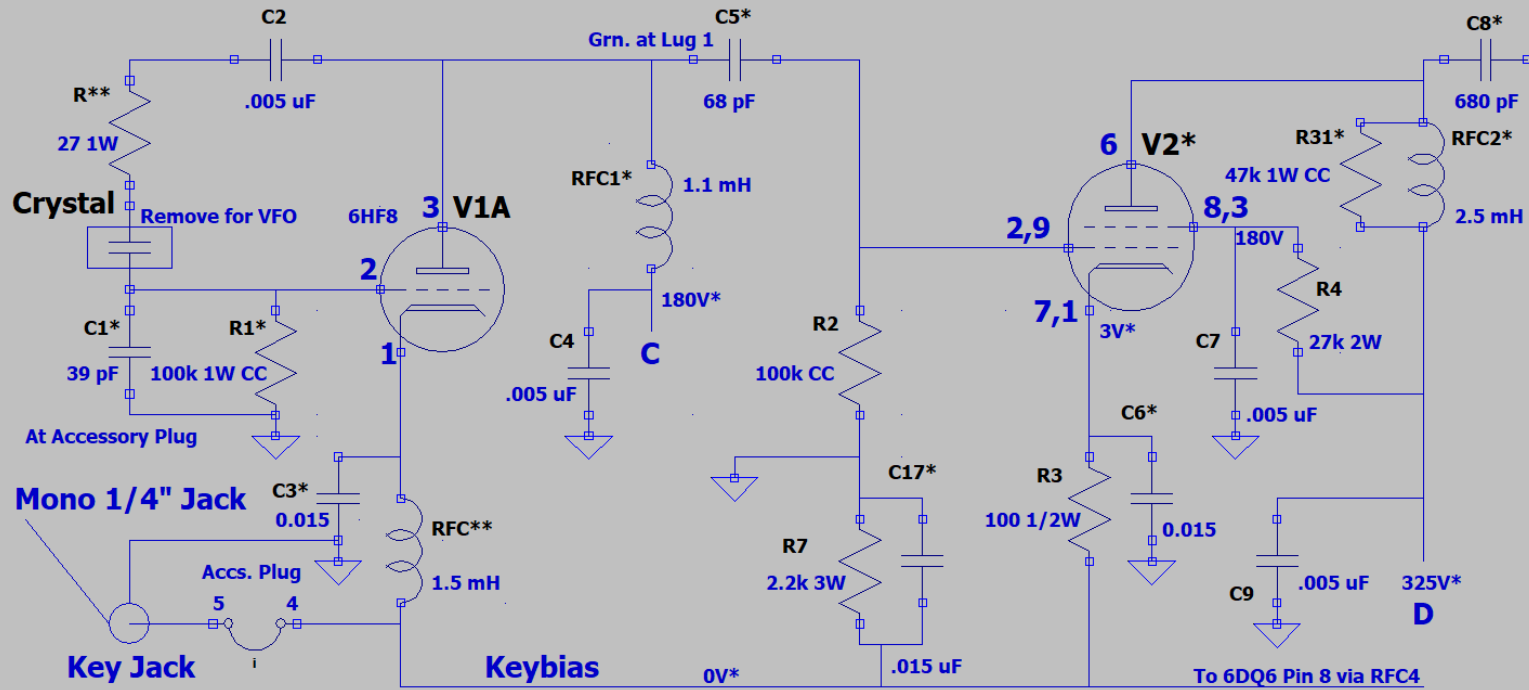

# Knight T- 60 6DQ6 Final Stage

PO AM Carrier = 18 Watts  
 PO AM 100% modulation = 36 Watts Peak

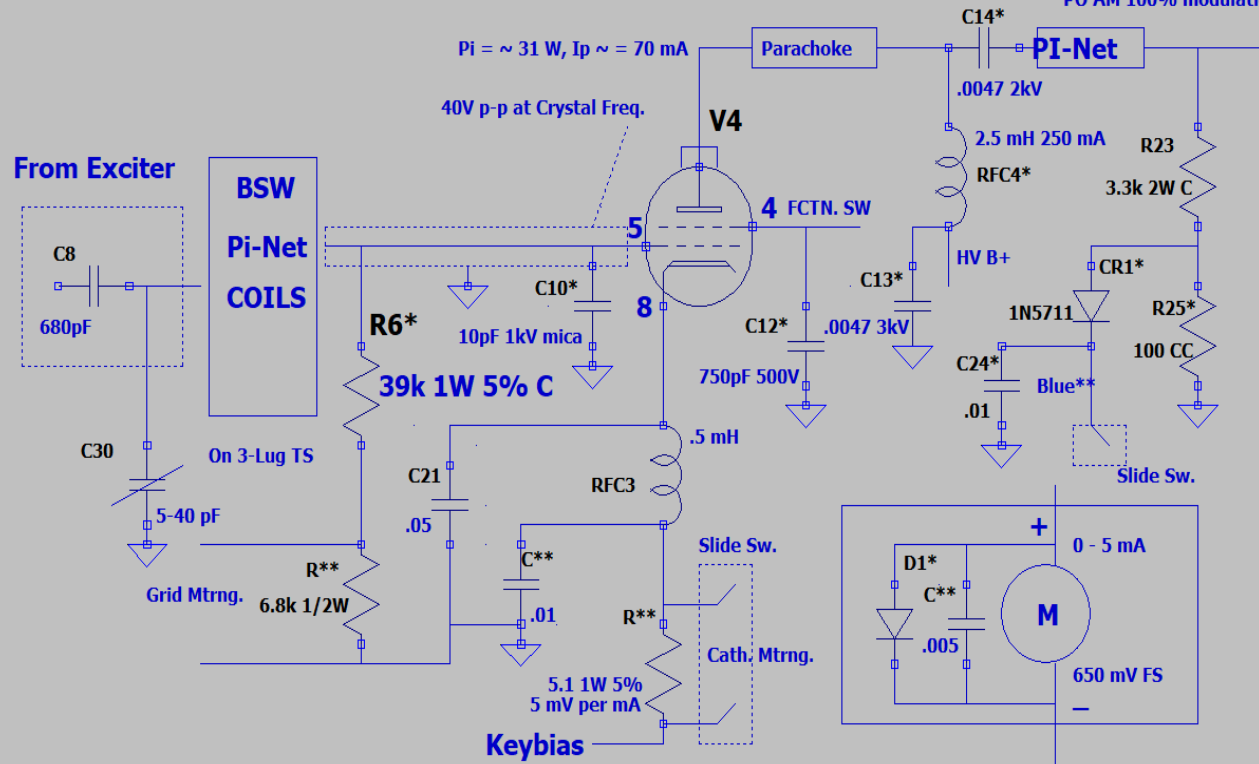

# Knight T- 60 Pi-Net

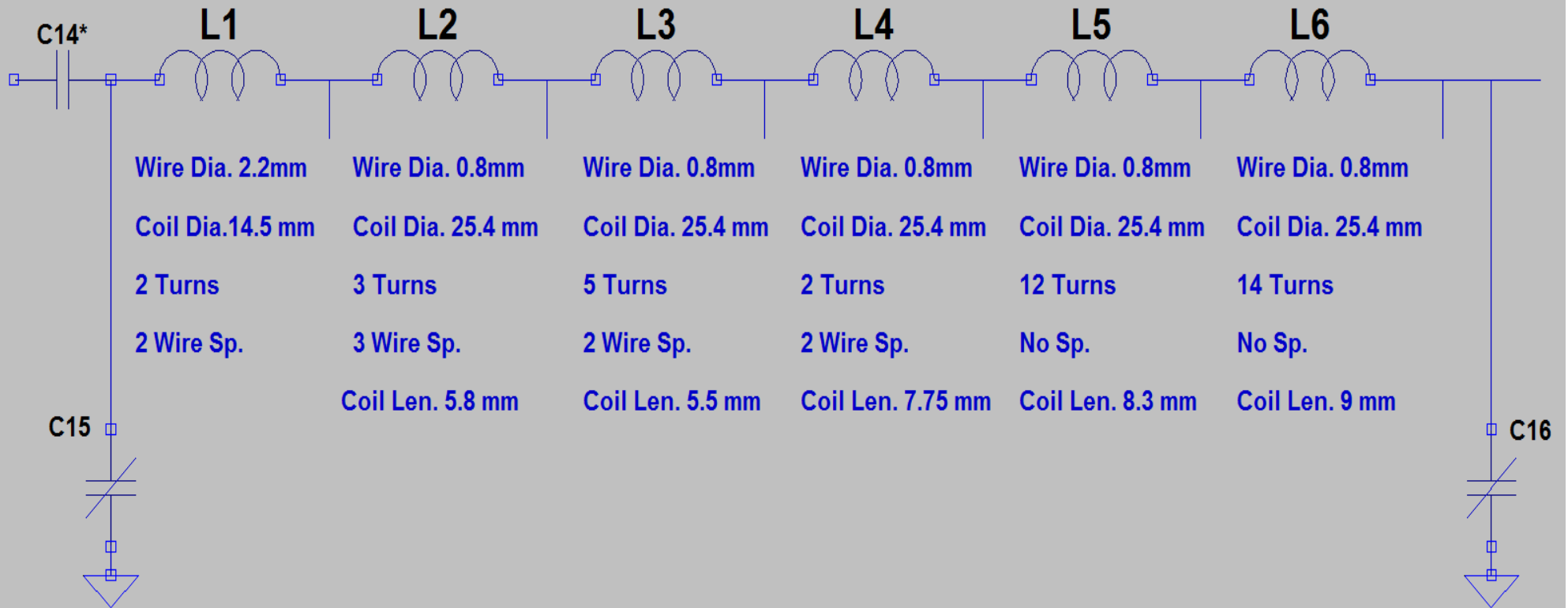

### Multiplication Operation:

On 80 meters the Osc. RF of 80m is driven to the sum of L1-L5 and L6, L8 so the fundamental gets through to the antenna.

On 40 meters the Osc. RF of 40m RF is driven to the sum of L2-L5 and one section of L6 is shorted, so the fundamental gets through to the antenna.

On 20 meters the Osc. presents a 40m signal to the sum of L3-L5 and two sections of L6 are shorted. So 2 X the fundamental gets through to the antenna.

On 15 meters the Osc. presents a 40m signal to the sum of L4-L5 and three sections of L6 are shorted. So 3 X the fundamental gets through to the antenna.

On 10 meters the Osc. presents a 40m signal to the sum of L3-L5 and four sections of L6 are shorted. So only 4 X the fundamental gets through to the antenna.

On 6 meters the Osc. presents an 8Mhz signal to L5 and five sections of L6 are shorted; only L8 is active. So only about 6.15 X the fundamental gets through to the antenna.

So, the two Pi sections resonance tuning determines what frequency gets passed to the antenna port.

A number of components were added or modified for a simple transmitter, but this AM QRP rig now has better audio and higher RF output.